

SR700 - Single Room Heat Recovery Unit

Easy to install, duct free ventilation solution



For use in residential dwellings

The SR700 from Titon is a decentralised ventilation unit with heat recovery providing continuous airflow to your home. It extracts stale, moist and contaminated air and replaces it with warmed fresh air from outside, improving indoor air quality and keeping heating costs down.

The system is easily installed and maintained, ideal for removing internal condensation and eliminating mould growth within the home. Unlike regular extractor fans that waste 100% of heat that passes through them, the SR700 system will recover up to *87% of wasted heat and create a comfortable living environment. It is recommended that the system is designed in pairs to allow for the system to work to its full capability.

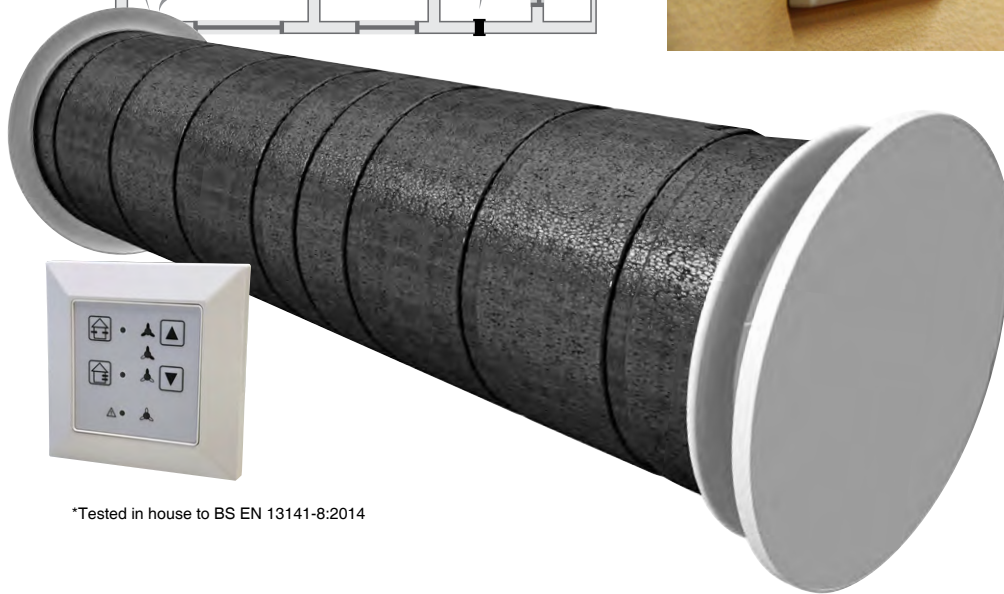
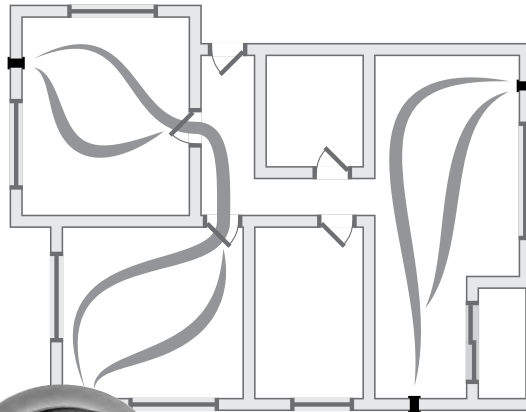

*Tested in house to BS EN 13141-8:2014

Features & Benefits

- Easy to maintain
- Low noise and vibration levels due to expanded polypropylene housing
- Low profile wall mounted fascia
- No additional ductwork required
- 'Sleep mode' function. By putting the unit to sleep, fans can be configured to either stop (default) or slow to humidity protection level for a period of time (default 1 hour) after which they will return to the previous setting
- 'Intensive speed' (Manual) to quickly remove any odours that are present.
- 'Intensive speed' (Automatic) to quickly remove excessive amounts of poor air, moisture and dangerous levels of Carbon Dioxide from within the home. (Sensors required).
- 'Cross ventilation' for a constant flow of fresh air through the house (No heat recovery)
- Wall thickness: Min. 305mm - Max. 700mm+
- Achieves 20Pa back pressure as per BS EN 13141-8:2014
- SR700 controller can connect up to 6 fans



Aesthetically pleasing design, offering efficient airflow and heat recovery during the winter and fresh air during the summer.

Drawing & Dimensions

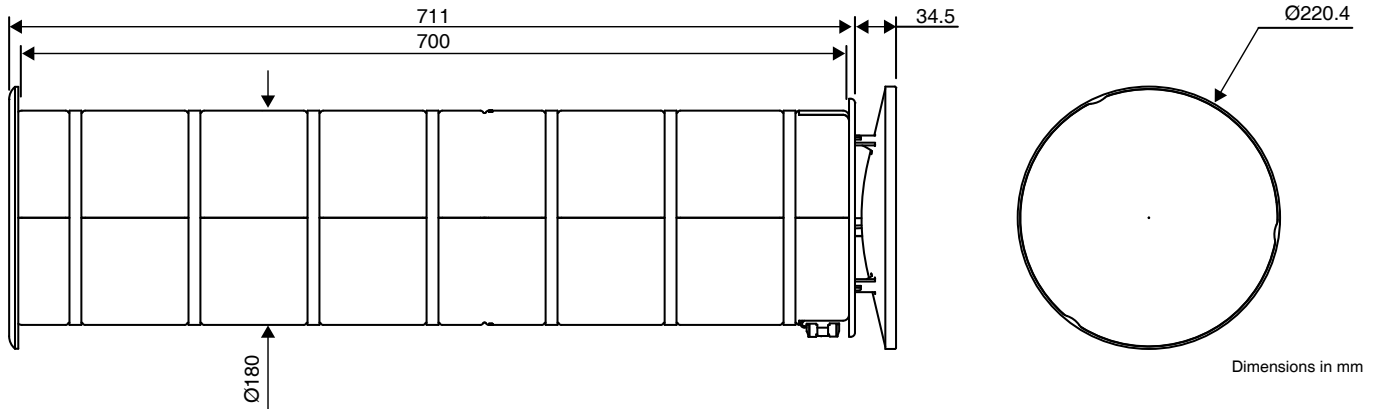

Product Codes

TP600 - SR700

TP590 - SRC1 (Control unit)

XP2010838 - Replacement PM Coarse 35% (G2) filter

XP2010320 - Replacement insect filter

TP610 - Relative humidity (RH) sensor (surface mount)

TP614 - Relative humidity (RH) sensor (flush mount)

TP611 - Carbon dioxide (CO₂) sensor (surface mount)

TP615 - Carbon dioxide (CO₂) sensor (flush mount)

TP612 - Combined relative humidity(RH) and Carbon dioxide (CO₂) sensor (surface mount)

TP616 - Combined relative humidity(RH) and Carbon dioxide (CO₂) sensor (flush mount)

TP613 - Air quality sensor (surface mount)

TP617 - Volatile organic compound (VOC)/Air quality sensor (flush mount) quality sensor (flush mount)

Standards

BS EN 13141-8:2014 (Ventilation for buildings)

EN 55014-1:2006 inc A1:2009 & A2:2011

EN 55014-2:2015 category IV

EN 61000-3-2:2014

EN 61000-3-3:2013 (Electromagnetic compatibility [EMC])

BS EN ISO 717-1:2013

BS EN ISO 10140-2:2010

BS EN ISO 3741:2010 (Acoustics)

IEC 60335-2-80:2002 +A1:2004, +A2:2008 in conjunction with IEC 60335-1:2010

BS EN 60335-2-80:2003 +A1:2004, +A2:2009 in conjunction with EN 60335-1:2012/AC:2014 +A11:2014

BS EN 62233 (Electrical Safety)

CE Marked

Specification

Dimensions: 711 long x Ø180 inside wall & Ø220mm x 35mm internal fascia

Weight: SR700 - 3Kg, SRC1 controller - 94g

Materials:

Tube: Expanded polypropylene (EPP)

Components: White ABS plastic

Heat exchanger: Ceramic

Filters: Synthetic

Internal insulation: Closed cell foamed nitrile

Fascia plate: White Perspex

Guarantee period: 2 years

Electrical: 230V ~ 50/60Hz, 3A fuse

Installation: The Titon SRHRV Fan unit is designed to be mounted through a wall with a thickness between 305mm & 700mm.

Maintenance: Easy to maintain. Routine service and filter clean/ replacement are all that are normally required to keep the SRHRV System working efficiently. Subject to local environment - see product manual.

Performance and Acoustic Data

Product	Fan Speed Setting	Airflow (m ³ /h)	dB(A) Max @ 3m Hemispherical	SFP (W/l/s) @0 pa
SR700	Fan Setting 1 (Large Dwelling)			
	*Sleep Mode	6.5 or off	8/0	0.62
	*Off	-	-	-
	Humidity protection	6.5	8	0.62
	Reduced	20	19	0.27
	Nominal	40	32	0.22
	Intensive	60	39	0.24
	Fan Setting 2 (Small Dwelling)			
	*Sleep Mode	6.5 or off	8/0	0.62
	*Off	-	-	-
	Humidity protection	6.5	8	0.64
	Reduced	10	11	0.44
	Nominal	17	18	0.3
	Intensive	25	24	0.24

*Configurable option

Airborne sound insulation. Rating according to: BS EN ISO 717-1:2013 & BS EN ISO 10140-2:2010	
Status	D _{n,e,w} (c;ctr)
Unit Open	34dB
Unit Closed	51dB

SRC1 Controller

A system consists of a central control unit which manages between 1 and 3 off pairs of through the wall 12V --- (dc) bidirectional fan units which are typically fitted in pairs so that they can provide cross flow ventilation within the home.

A controlled ventilation system such as the SR700 from Titon meets the criteria for low energy housing and is ideal for installing during refurbishment of a home.



SRC1 (Control unit) - TP590

Sensors



Flush mount



Surface mount

Sensor Description	Flush Mount	Surface mount
Relative humidity (RH) Sensor	TP614	TP610
Carbon dioxide (CO ₂) Sensor	TP615	TP611
Combined relative humidity(RH) and Carbon Dioxide (CO ₂) Sensor	TP616	TP612
Volatile organic compound (VOC)/Air Quality Sensor	TP617	TP613